

# APPLIANCE HOLDER STEGOFIX PLUS

## SFP 095



Screw mounting



Self-adhesive tape mounting



Magnet mounting



Application example

- > Alternative to 35 mm DIN rail
- > Easy/flexible installation
- > For devices and sockets with DIN rail mounting clip
- > Screw mounting
- > Self-adhesive tape mounting
- > Magnet mounting

The appliance holder STEGOFIX PLUS is the flexible alternative to a 35 mm DIN rail. It allows for a quick and easy installation of small devices or accessory equipment intended for DIN rail mounting. STEGOFIX PLUS is suitable for devices with a clip width of max. 66 mm, offering a convenient mounting method for almost any application: screw mounting with 25 mm pitch, high-performance adhesive tape or rubberized neodymium magnets.



### TECHNICAL DATA

Areas of application	devices with DIN rail mounting clip suitable for a 35 mm DIN rail according to EN 60715, max. clip width 66 mm
Mounting	
> Screw mounting	e.g. tapping screws DIN 7981 (ISO 7049), Ø 5.5 mm; thread-forming screws DIN 7500, M5; (not included in delivery)
> Self-adhesive tape mounting	adhesive surface 65 x 25 mm
> Magnet mounting	2 neodymium magnets, rubberized
Material	plastic according to UL94 V-0, black
Dimensions	71 x 40 x 15 mm
Operating temperature	-35 to +75 °C (-31 to +167 °F)
Storage conditions (self-adhesive tape)	optimal storage conditions for self-adhesive tape approx. +20 °C (+68 °F) at 50 % RH
Approvals	EAC
Note	Material adheres to limit values in accordance with RoHS3

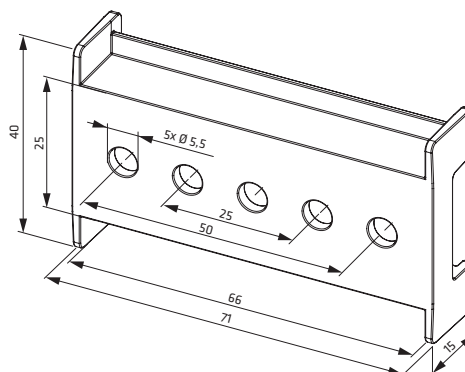

Art. No.	Model	Max. Holding force <sup>1</sup>	1 packing unit	Weight (approx.)
09550.0-05	Screw mounting	-	5 pieces	65 g (13 g / piece)
09550.1-05	Self-adhesive tape mounting	75 N	5 pieces	70 g (14 g / piece)
09550.2-05	Magnet mounting	30 N	5 pieces	145 g (29 g / piece)